

Wheel Loader LG936L

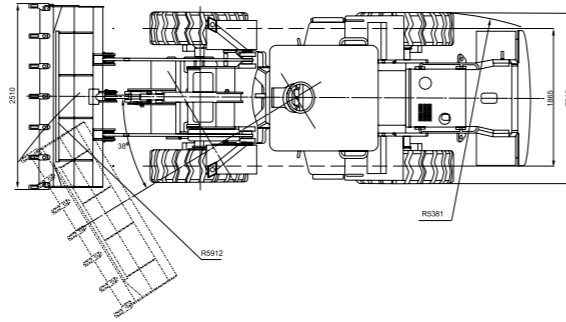

Item	Specifications
Performance	
Overall Working Weight	10,700kg
Rated Bucket Capacity	1.8m ³
Rated Lift Capacity	3,000kg
Maximum Traction Force	≥ 105kN
Maximum Breakout Force	≥ 96kN
Maximum Gradeability	30°
Maximum Dumping Height	2950mm
Dumping Distance	1050mm
Overall Dimension (L x W x H)	7100 x 2500 x 3170mm
Engine	
Model	Weichai WP6G125E22
Type	4 stroke, turbocharged, water-cooled, direct injection diesel engine
Number of Cylinders	6
Bore / Stroke	105 x 120mm
Maximum Torque	500N.m
Rated Power	92kW
Rated Rotation Speed	2200rpm
Transmission System	
Model	SDLG A301
Type, Gear Shift	Powershift, 2F / 1R
Torque Conversion Ratio	4.56:1
Maximum Forward Velocity	38km/h
Fluid Capacity	
Fuel Tank	140L
Hydraulic Oil Tank	130L

Item	Specifications
Front & Rear Axle	
Model	SDLG A300
Tyre	
Size	17.5 / 25
Tyre Pressure	0.33MPa / 0.27MPa
Steering System	
Type	Hydrostatic Articulated
Steering Angle	38°
Minimum Turning Radius (Without Bucket)	5381mm
Minimum Turning Radius (With Bucket)	5912mm
Hydraulic System	
Pressure	16MPa / 160bar
Hydraulic Drive	Pilot Control Joystick
3rd Function	Available (Connection Optional)
Brake System	
Service Brake	Dry disc type, double circuit air over hydraulic
Park Brake	Dry disc type, spring applied and air released via control button

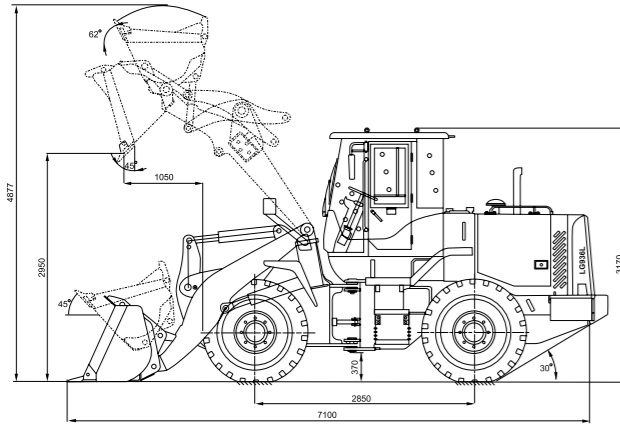

Reliability in Action

WHEEL LOADER LG936L



Wheel Loader LG936L



Instrument panel

The instrument panel is fully digital ensuring precise operator control. It is integrated with the entire machine for ease of inspection and maintenance.

Cab

The new fully-covered steel cab has been redesigned with better visibility, more spacious and enhanced interior trimmings.

Advanced steering system

Fully hydraulic with load-sensing capability, improving operator comfort and efficiency. The double sealed pipeline increases reliability.

Engine

High performance and reliable Weichai DEUTZ turbocharged engine meeting Tier II emission standard.

Bucket

Large capacity bucket combined with protruding type cutting board. Reinforced anti-friction plate reduces cutting resistance improving productivity.

Transmission

The SDLG 5T planetary transmission is designed with two forward and one reverse gear shifts positions. Coupled with single-stage four-element twin-turbo hydraulic torque converter, large torque ratio and high transmission efficiency.

Frame

Reinforced frame has passed 200,000 fatigue enhancement tests to ensure strong bearing capacity, good load distribution and stability.